



INDIANO
WATER MANAGEMENT EXPERT



BRASS FORGED
BALL VALVE

AN ISO 9001 : 2015 CERTIFIED COMPANY
AN IPA MEMBER COMPANY



Welcome to world of **INDIANO**[®] water valves.

INDIANO[®] brass ball valves are Compact, heavy duty, simple & cost effective. INDIANO[®] brass ball valves are full flow, quarter turn, handle operated, general purpose ball valves to control or stop the flow of liquid or gas in any piping systems. These valves are manufactured from forgings of graded brass extruded rods and machined on highly accurate CNC machines to achieve international standard quality.

INDIANO[®] brass ball valves are manufactured by ABHILASHA FORGING - Jamnagar (INDIA). These valves are designed and developed according to International standard EN 13547-2013.

The design construction of valve is competent to achieve 25 Bar flow pressure of water.

100 % valves are tested at 6 bar air pressure according to standard EN 12266-1.

***INDIANO[®] VALVES ARE SAFE FOR DRINKING WATER APPLICATIONS.**

Installation

» INDIANO[®] brass ball valves can be installed bi-directional.

Size Specification

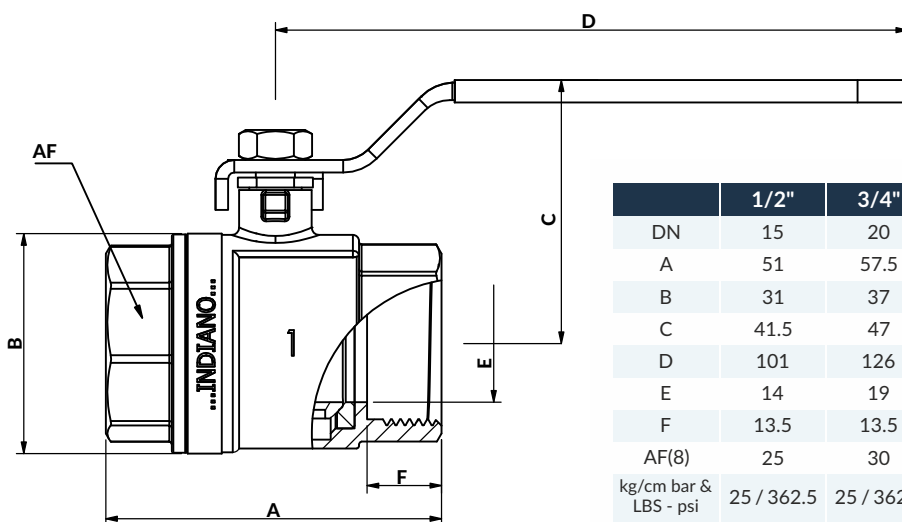

	1/2"	3/4"	1"	1 1/4"	1 1/2"	2"
DN	15	20	25	32	40	50
A	51	57.5	67	76	89	105
B	31	37	44	55	65	82
C	41.5	47	51	70	75	84
D	101	126	126	178	178	200
E	14	19	23.5	30	37	48
F	13.5	13.5	15	16	18	19
AF(8)	25	30	37	46	53	65
kg/cm bar & LBS - psi	25 / 362.5	25 / 362.5	25 / 362.5	25 / 362.5	25 / 362.5	25 / 362.5

(All dimensions are in mm)

BRASS FORGED BALL VALVE



**RUST PROOF
DACROMET® COATED**

Specifications

- » Material - Full brass forged body. (Nickel plated)
- » Seat ring – Virgin PTFE (Teflon).
- » Lever – Dacromet® coated steel handle.
- » Spindle – Blow out proof.
- » Ball – Super finish chrome plated
- » End threads – BSP to ISO 228 at both ends.
- » Temp. Working: -20 to 180 degree C.
- » Pressure rating – 25 Bar (at 60 degree C).
- » Material grade, size & pressure rating permanently roll marked on the surface.
- » Dust and thread protection Cap.

Benefits

- » INDIANO® valves are highly corrosion (rust) resistance with hard water contact.
- » INDIANO® valves are designed such that no leakage at low pressure.
- » INDIANO® valves are manufactured from low lead content brass (CW 617N) and are safe for drinking water and health.
- » INDIANO® valves are easy to fit and replace with standard pipe threads.

Material Specification

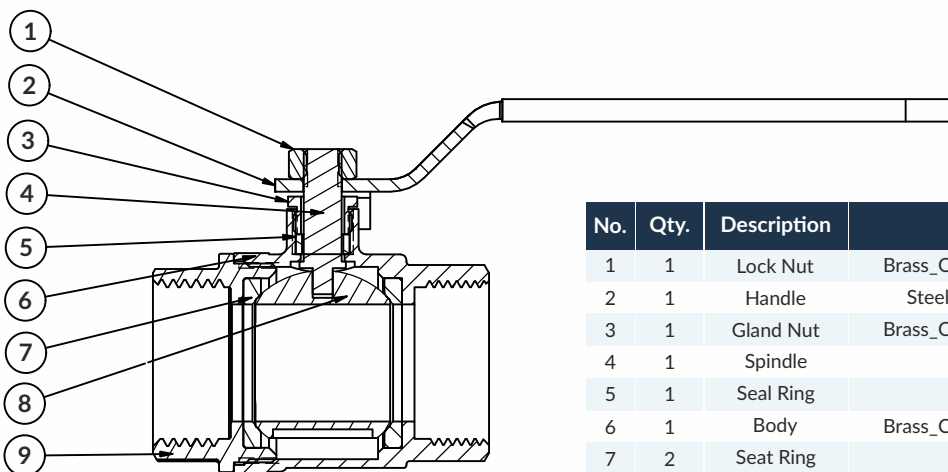

No.	Qty.	Description	Material	Standard
1	1	Lock Nut	Brass_CW614N (Nickel Plated)	EN 12165
2	1	Handle	Steel (Dacromet® Coated)	EN 10111
3	1	Gland Nut	Brass_CW614N (Nickel Plated)	EN 12165
4	1	Spindle	Brass_CW614N	EN 12165
5	1	Seal Ring	PTFE	-
6	1	Body	Brass_CW617N (Nickel Plated)	EN 12165
7	2	Seat Ring	PTFE	-
8	1	Ball	Brass_CW617N (Polished NiCr Plated)	EN 12165
9	1	Nut	Brass_CW617N (Nickel Plated)	EN 12165



Manufactured by :

ABHILASHA FORGING

16, G.I.D.C. Phase - 2, Dared Jamnagar - 361005 (Guj.) INDIA.

Phone : +91 99792 56730

E-mail : info@abhilashaforging.com

Web : www.abhilashaforging.com

Customer Care & Tel. : +91 (0288) 2730121

(An ISO 9001 Certified Company) An IPA Member Company